

Doc. Number :

- Tentative Specification
- Preliminary Specification
- Approval Specification

MODEL NO.: G057VGE
SUFFIX: T01

Customer:

APPROVED BY

SIGNATURE

Name / Title _____

Note

Please return 1 copy for your confirmation with your signature and comments.

Approved By	Checked By	Prepared By
KJ Cheng	Pam Liang	Miyabi Ko

- CONTENTS -

REVISION HISTORY	-----	3
1. GENERAL DESCRIPTION	-----	4
1.1 OVERVIEW		
1.2 FEATURES		
1.3 APPLICATION		
1.4 GENERAL SPECIFICATIONS		
1.5 MECHANICAL SPECIFICATIONS		
2. ABSOLUTE MAXIMUM RATINGS	-----	6
2.1 ABSOLUTE RATINGS OF ENVIRONMENT		
2.2 ELECTRICAL ABSOLUTE RATINGS		
2.2.1 TFT LCD MODULE		
2.2.2 BACKLIGHT UNIT		
3. ELECTRICAL CHARACTERISTICS	-----	8
3.1 TFT LCD MODULE		
3.2 BACKLIGHT UNIT		
4. BLOCK DIAGRAM	-----	9
4.1 TFT LCD MODULE		
5. INPUT TERMINAL PIN ASSIGNMENT	-----	11
5.1 TFT LCD MODULE		
5.2 BACKLIGHT UNIT		
5.3 COLOR DATA INPUT ASSIGNMENT		
6. INTERFACE TIMING	-----	14
6.1 INPUT SIGNAL TIMING SPECIFICATIONS		
6.2 POWER ON/OFF SEQUENCE		
6.3 THE INPUT DATA FORMAT		
6.4 SCANNING DIRECTION		
7. OPTICAL CHARACTERISTICS	-----	18
7.1 TEST CONDITIONS		
7.2 OPTICAL SPECIFICATIONS		
8. RELIABILITY TEST CRITERIA	-----	22
9. PACKAGING	-----	23
9.1 PACKING SPECIFICATIONS		
9.2 PACKING METHOD		
9.3 UN-PACKING METHOD		
10. DEFINITION OF LABELS	-----	26
11. PRECAUTIONS	-----	27
11.1 ASSEMBLY AND HANDLING PRECAUTIONS		
11.2 SAFETY PRECAUTIONS		
12. MECHANICAL CHARACTERISTICS	-----	28

REVISION HISTORY

Version	Date	Page	Description
1.0	Dec 05, 2012	All	G057VGE-T01 Tentative Spec. was first issued
1.1	Dec 24, 2012	18	Optical spec.
1.2	Jan 29 , 2013	4	1.1 interface mode.
1.3	Jan 30 , 2013	15	6.2 Input signal timing diagram
1.4	Mar 1 , 2013	5	1.5 Mechanical Specification.
		18	7.2 Optical Specifications
		27	12. Mechanical Characteristic
1.5	Apr. 23, 2013	28	12. Mechanical characteristic
		25	9.3 Un-packing method
		18	7.2 Optical specifications
		12	5.2 Backlight unit
2.0	Jun. 25, 2013	7	2.2. Electrical absolute ratings
		8	3.1 TFT LCD Module electrical characteristics
		9	3.2 Backlight unit electrical characteristics
		18	7.2 Optical specifications
		26	10. Definitions of label
		28	12. Mechanical characteristics
2.1	Jul. 12, 2013	9	3.2 Backlight unit electrical characteristics
2.2	Aug. 9, 2013	11	5.1 TFT LCD Module
2.3	Mar 13 ,2014	6	2.1 ABSOLUTE RATINGS OF ENVIRONMENT
		8	3.1 TFT LCD MODULE
		9	3.2 BACKLIGHT UNIT
		11	5.1 TFT LCD MODULE
		12	5.2 BACKLIGHT UNIT (Converter connector pin)
		13	5.2 BACKLIGHT UNIT
		23	9.1 PACKING SPECIFICATIONS
			9.2 PACKING METHOD
		28	12. MECHANICAL CHARACTERISTICS

1. GENERAL DESCRIPTION

1.1 OVERVIEW

The G057VGE-T01 model is a 5.7" TFT-LCD module with a white LED Backlight Unit and a 33-pin 1ch-TTL interface. This module supports 640 x 480 VGA mode and displays 262K colors. The converter for the Backlight Unit is built in.

1.2 FEATURES

- Wide viewing angle
- High contrast ratio
- Fast response time
- VGA (640 x 480 pixels) resolution
- Wide operating temperature
- DE (Data Enable) mode and DE+SYNC mode
- TTL interface
- Reversible scan direction
- RoHS Compliance

1.3 APPLICATION

- TFT LCD Monitor
- Industrial Application

1.4 GENERAL SPECIFICATIONS

Item	Specification	Unit	Note
Diagonal Size	5.7	inch	
Active Area	115.2(H) x 86.4(V)	mm	
Bezel Opening Area	118.2(H) x 89.4(V)	mm	
Driver Element	a-si TFT active matrix	-	-
Pixel Number	640 x R.G.B. x 480	pixel	-
Pixel Pitch	0.18(H) x 0.18(V)	mm	-
Pixel Arrangement	RGB stripe	-	-
Display Colors	262K	color	-
Transmissive Mode	Normally white	-	-
Surface Treatment	Anti-Glare coating (Haze 25)	-	-
Module Power Consumption	3.5	W	Typ.

1.5 MECHANICAL SPECIFICATIONS

Item		Min.	Typ.	Max.	Unit	Note
Module Size	Horizontal (H)	143.5	144	144.5	mm	(1)
	Vertical (V)	104.1	104.6	105.1	mm	
	Depth (D)	-	12.3	12.8	mm	
Weight			155	170	g	-
I/F connector mounting position		The mounting inclination of the connector makes the screen center within $\pm 0.5\text{mm}$ as the horizontal.			-	(2)

Note (1) Please refer to the attached drawings for more information of front and back outline dimensions.

(2) Connector mounting position

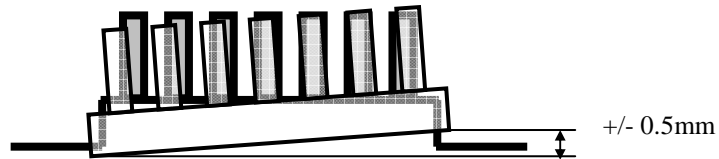

2. ABSOLUTE MAXIMUM RATINGS

2.1 ABSOLUTE RATINGS OF ENVIRONMENT

Item	Symbol	Value		Unit	Note
		Min.	Max.		
Operating Ambient Temperature	T _{OP}	-30	85	°C	
Storage Temperature	T _{ST}	-30	85	°C	

Note (1) Temperature and relative humidity range is shown in the figure below.

- (2) 90 %RH Max. (Ta < 40 °C).
- (3) Wet-bulb temperature should be 39 °C Max. (Ta < 40 °C).
- (4) No condensation.

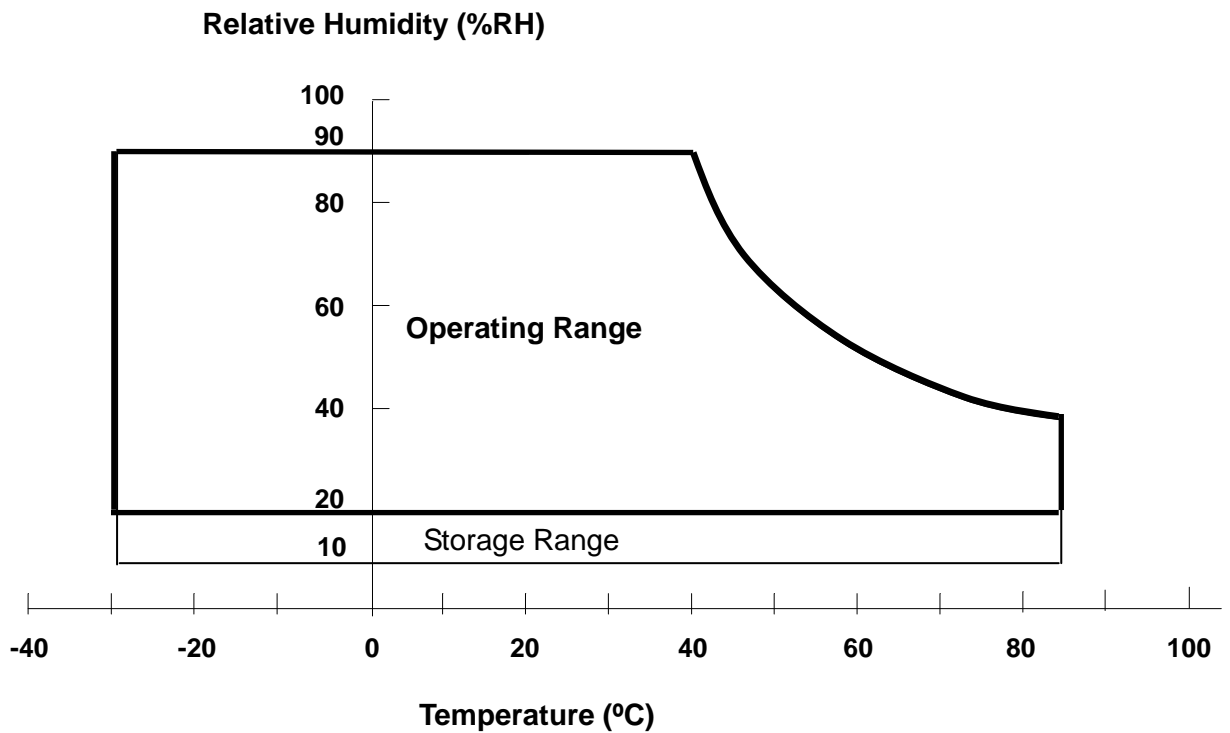

2.2 ELECTRICAL ABSOLUTE RATINGS

2.2.1 TFT LCD MODULE

Item	Symbol	Value		Unit	Note
		Min.	Max.		
Power Supply Voltage	VCC	-0.3	3.6	V	(1)

2.2.2 BACKLIGHT UNIT

Item	Symbol	Value		Unit	Note
		Min.	Max.		
Converter Voltage	V_i	-0.3	18	V	(1), (2)
Enable Voltage	EN	---	5.5	V	
Backlight Adjust	ADJ	---	5.5	V	

Note (1) Permanent damage to the device may occur if maximum values are exceeded. Function operation should be restricted to the conditions described under Normal Operating Conditions.

Note (2) Specified values are for lamp (Refer to 3.2 for further information).

3. ELECTRICAL CHARACTERISTICS

3.1 TFT LCD MODULE

Ta = 25 ± 2 °C

Parameter	Symbol	Value			Unit	Note
		Min.	Typ.	Max.		
Power Supply Voltage	V _{CC}	3.0	3.3	3.6	V	(1) at V _{CC} =3.3V
Rush Current	I _{RUSH}	-	-	1.5	A	(2)
Power Supply Current	White	-	140	190	mA	(3)a, at V _{CC} =3.3V
	Black	-	160	210	mA	(3)b, at V _{CC} =3.3V
Power Consumption	P _L	-	0.53	-	W	
Logic High Input Voltage	V _{IH}	0.7V _{CC}		V _{CC}	V	
Logic Low Input Voltage	V _{IL}	GND		0.3V _{CC}	V	

Note (1) The assembly should be always operated within above ranges.

Note (2) Measurement Conditions:

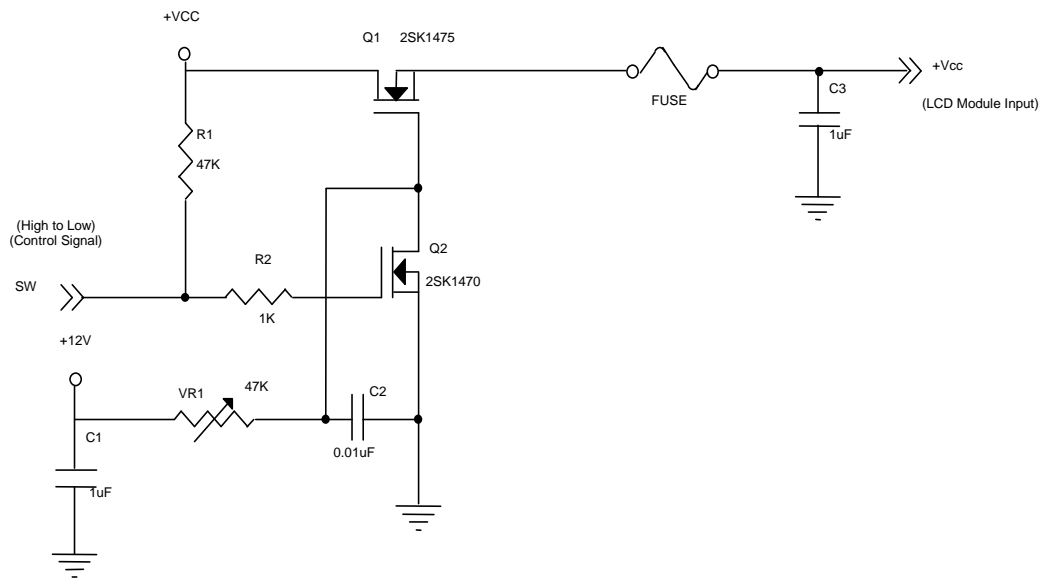

Vcc rising time is 470µs

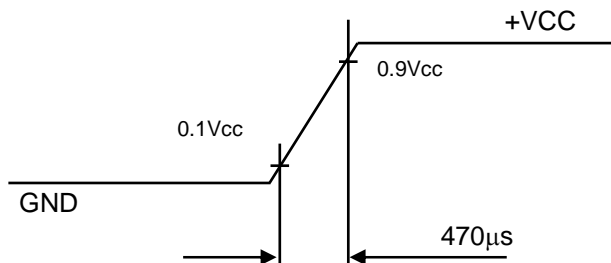

Note (3) The specified power supply current is under the conditions at $V_{cc} = 3.3V$, $T_a = 25 \pm 2 \text{ }^\circ\text{C}$, $f_v = 60 \text{ Hz}$, whereas a power dissipation check pattern below is displayed.

a. White Pattern



Active Area

b. Black Pattern

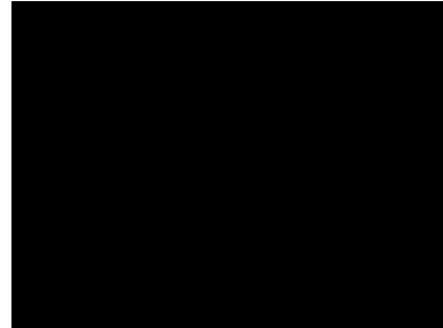

Active Area

3.2 BACKLIGHT UNIT

$T_a = 25 \pm 2 \text{ }^\circ\text{C}$

Parameter	Symbol	Value			Unit	Note
		Min.	Typ.	Max.		
Converter Power Supply Voltage	V_i	10.8	12	13.2	V	
Converter Power Supply Current	I_i	0.28	0.26	0.23	A	@ $V_i = 12V$ (Duty 100%)
LED Power Consumption	P_o		2.45		W	@ $V_i = 12V$ (Duty 100%)
EN Control Level	Backlight on	2.0	3.3	5.0	V	
	Backlight off	0	---	0.15	V	
PWM Control Level	PWM High Level	2.0	3.3	5.0	V	
	PWM Low Level	0	---	0.15	V	
PWM Control Duty Ratio	-	Note(3)		100	%	Note(3)
PWM Control Frequency	f_{PWM}	200		30K	Hz	Note(3)
LED Life Time	L_L	50000			Hrs	(2)

Note (1) LED current is measured by utilizing a high frequency current meter as shown below:

Note (2) The lifetime of LED is defined as the time when it continues to operate under the conditions at $T_a = 25 \pm 2 \text{ }^\circ\text{C}$ and Duty 100% until the brightness becomes $\leq 50\%$ of its original value. Operating LED under high temperature environment will reduce life time and lead to color shift.

Note (3) At 1K ~30KHz PWM control frequency, duty ratio range is restricted as below:

- 1K Hz ==> 2 %
- 10KHz ==> 20 %
- 20KHz ==> 40 %
- 30KHz ==> 60 %

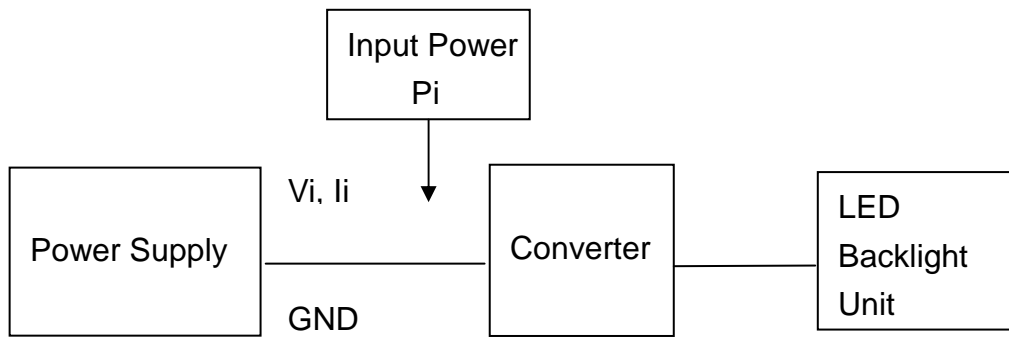

4. BLOCK DIAGRAM

4.1 TFT LCD MODULE

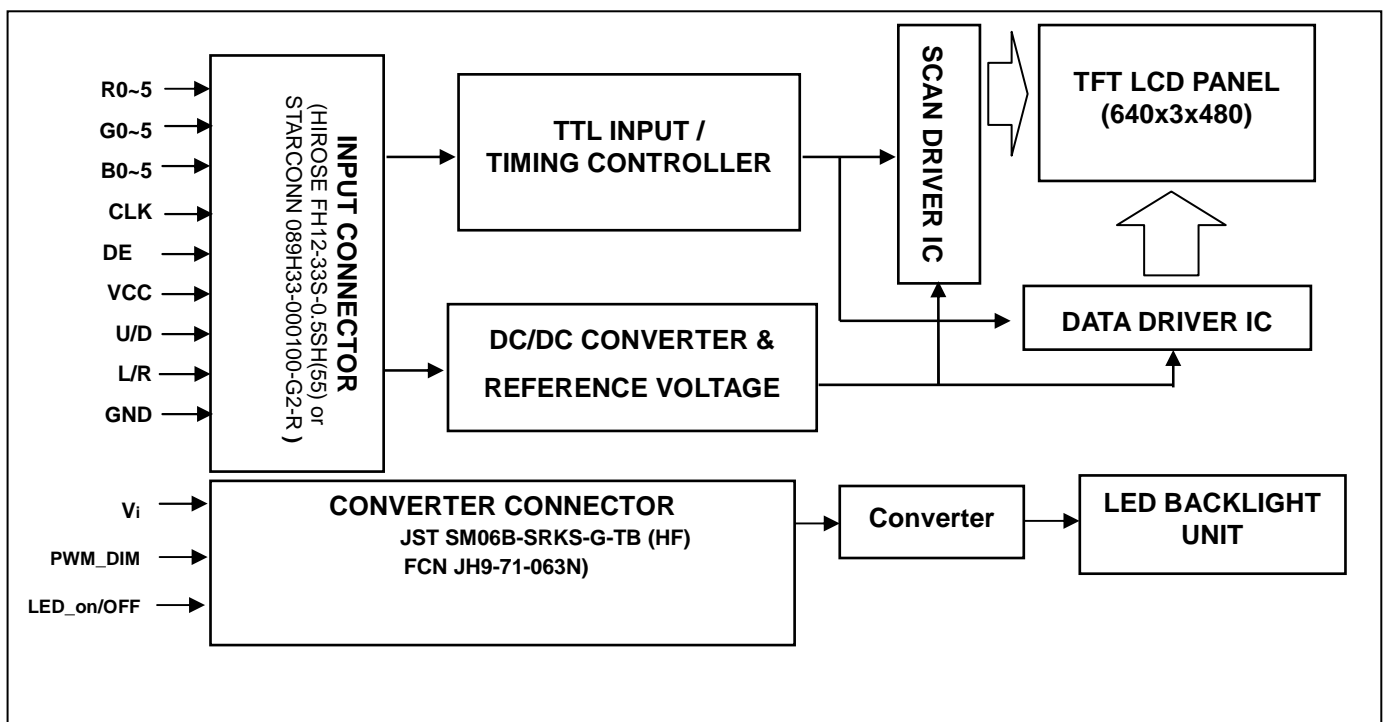

5. INPUT TERMINAL PIN ASSIGNMENT

5.1 TFT LCD MODULE

Pin	Name	Description	Remark
1	GND	Ground	
2	CLK	Dot Clock	
3	IHS	Horizontal synchronous signal	Note(4)
4	IVS	Vertical synchronous signal	Note(4)
5	GND	Ground	
6	R0	Red data (LSB)	
7	R1	Red data	
8	R2	Red data	
9	R3	Red data	
10	R4	Red data	
11	R5	Red data (MSB)	
12	GND	Ground	
13	G0	Green data (LSB)	
14	G1	Green data	
15	G2	Green data	
16	G3	Green data	
17	G4	Green data	
18	G5	Green data (MSB)	
19	GND	Ground	
20	B0	Blue data (LSB)	
21	B1	Blue data	
22	B2	Blue data	
23	B3	Blue data	
24	B4	Blue data	
25	B5	Blue data (MSB)	
26	GND	Ground	
27	DE	Data Enable Signal	
28	VDD	Power Supply (3.3V)	
29	VDD	Power Supply (3.3V)	
30	R/L	Horizontal reverse scan	Note (5)
31	U/D	Vertical reverse scan	Note (5)
32	NC	Not Connect	Note (3)
33	GND	Ground	

Note (1) Connector Part No.: HIROSE FH12-33S-0.5SH(55) or equivalent.

Note (2) "Low" stands for 0V. "High" stands for 3.3V. "NC" stands for "No Connected".

Note (3) DE Only Mode or DE + Sync Mode

Note (4)a. DIP Switch for Two types or four types reverse scan Option.

b. Interface optional pin has internal scheme as following diagram, Customer should keep the interface voltage level requirement which including panel board loading as below.

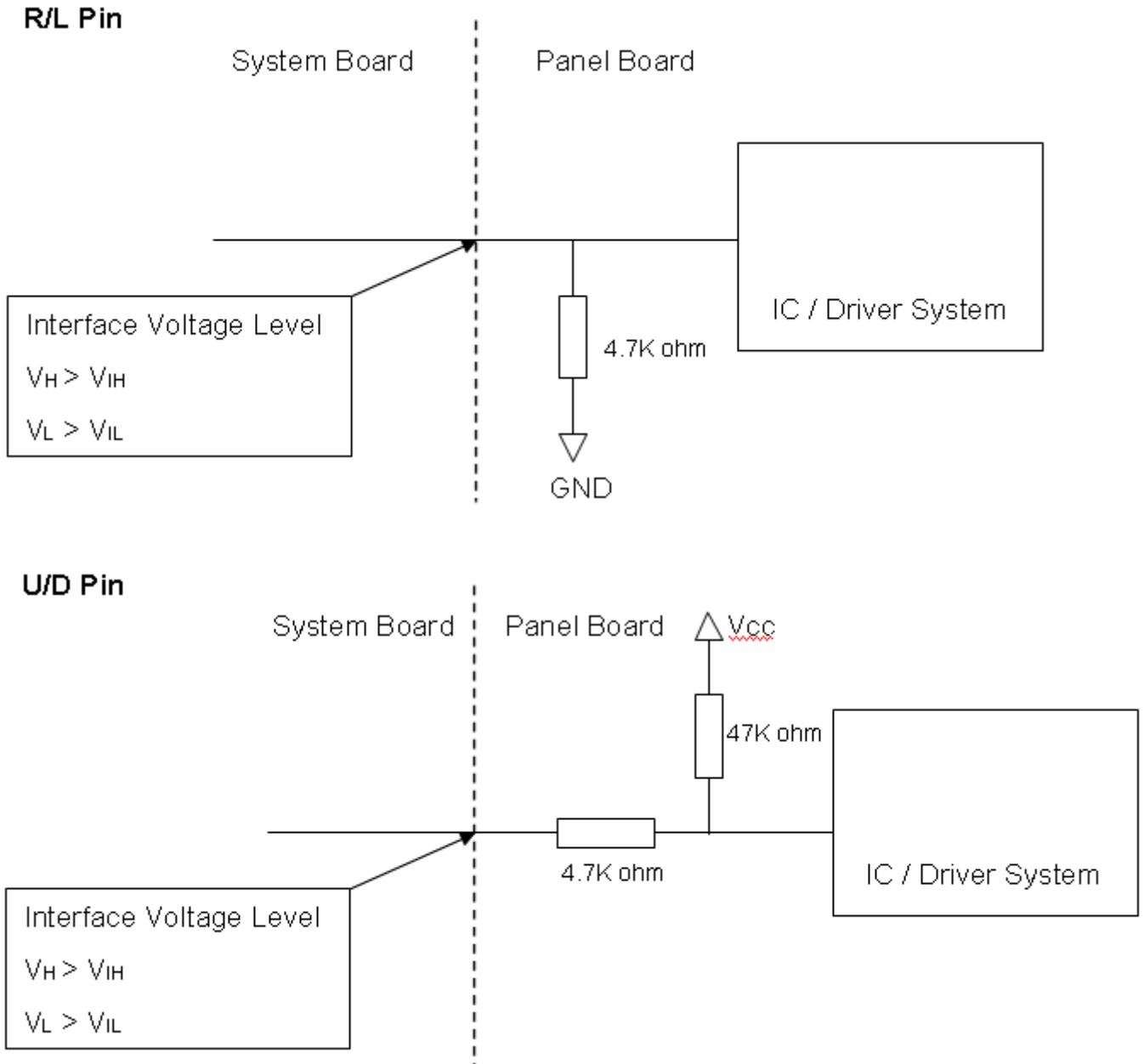

5.2 BACKLIGHT UNIT (Converter connector pin) JST SM06B-SRKS-G-TB (HF)

Pin	Symbol	Description	Remark
1	V_i	Converter input voltage	12V
2	V_i	Converter input voltage	12V
3	V_{GND}	Converter ground	Ground
4	V_{GND}	Converter ground	Ground
5	ADJ	Backlight Adjust	PWM Dimming
6	EN	Backlight Enable	LED On/Off

5.3 DIP Switch for Reverse scan function option

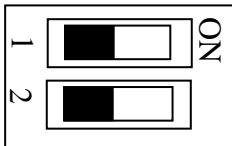

(1) Switch 1

ON : NA

OFF : NA

(2) Switch 2

ON : 2 types reverse scan as the Fig.5 & Fig.6 (U/D must be "OPEN")

OFF : 4 types reverse scan as the Fig.1~4

The following figures show the image see from the front view. The arrow indicates the direction of scan.

Fig.1 Normal Scan

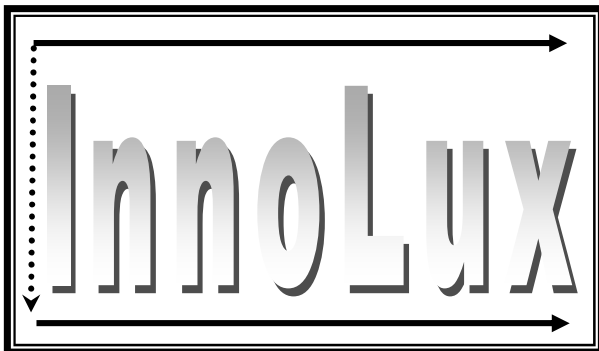

Fig.2 Reverse scan



Fig.3 Reverse scan



Fig.4 Reverse scan



Fig. 1 Normal scan (R/L=Low or NC, U/D = High or NC)

Fig. 2 Reverse scan (R/L=High, U/D = High or NC)

Fig. 3 Reverse scan (R/L=Low or NC, U/D = Low)

Fig. 4 Reverse scan (R/L=High, U/D = Low)

The following figures show the image see from the front view. The arrow indicates the direction of scan.

Fig.5 Normal Scan

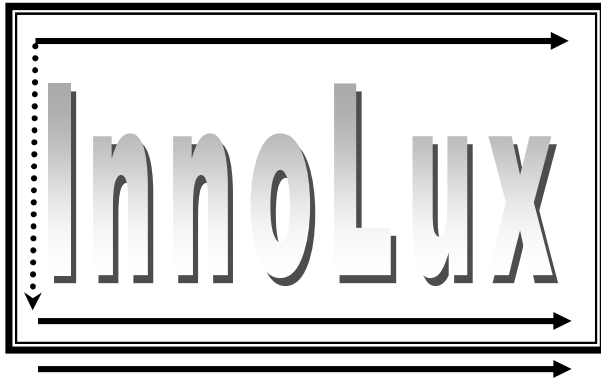

Fig. 5 Normal scan (RL=Low or NC)

Fig.6 Reverse Scan



Fig. 6 Reverse scan (RL=High)

5.4 COLOR DATA INPUT ASSIGNMENT

The brightness of each primary color (red, green and blue) is based on the 6-bit gray scale data input for the color. The higher the binary input, the brighter the color. The table below provides the assignment of color versus data input.

Color		Data Signal																	
		Red						Green						Blue					
		R5	R4	R3	R2	R1	R0	G5	G4	G3	G2	G1	G0	B5	B4	B3	B2	B1	B0
Basic Colors	Black	0	0	0	0	0	0	0	0	0	0	0	0	0	0	0	0	0	0
	Red	1	1	1	1	1	1	0	0	0	0	0	0	0	0	0	0	0	0
	Green	0	0	0	0	0	0	1	1	1	1	1	1	0	0	0	0	0	0
	Blue	0	0	0	0	0	0	0	0	0	0	0	0	1	1	1	1	1	1
	Cyan	0	0	0	0	0	0	1	1	1	1	1	1	1	1	1	1	1	1
	Magenta	1	1	1	1	1	1	0	0	0	0	0	0	0	1	1	1	1	1
	Yellow	1	1	1	1	1	1	1	1	1	1	1	1	0	0	0	0	0	0
	White	1	1	1	1	1	1	1	1	1	1	1	1	1	1	1	1	1	1
Gray Scale Of Red	Red(0)/Dark	0	0	0	0	0	0	0	0	0	0	0	0	0	0	0	0	0	0
	Red(1)	0	0	0	0	0	1	0	0	0	0	0	0	0	0	0	0	0	0
	Red(2)	0	0	0	0	1	0	0	0	0	0	0	0	0	0	0	0	0	0
	:	:	:	:	:	:	:	:	:	:	:	:	:	:	:	:	:	:	:
	:	:	:	:	:	:	:	:	:	:	:	:	:	:	:	:	:	:	:
	:	:	:	:	:	:	:	:	:	:	:	:	:	:	:	:	:	:	:
	Red(61)	1	1	1	1	0	1	0	0	0	0	0	0	0	0	0	0	0	0
	Red(62)	1	1	1	1	1	0	0	0	0	0	0	0	0	0	0	0	0	0
Red(63)	1	1	1	1	1	1	0	0	0	0	0	0	0	0	0	0	0	0	
Gray Scale Of Green	Green(0)/Dark	0	0	0	0	0	0	0	0	0	0	0	0	0	0	0	0	0	0
	Green(1)	0	0	0	0	0	0	0	0	0	0	0	1	0	0	0	0	0	0
	Green(2)	0	0	0	0	0	0	0	0	0	0	1	0	0	0	0	0	0	0
	:	:	:	:	:	:	:	:	:	:	:	:	:	:	:	:	:	:	:
	:	:	:	:	:	:	:	:	:	:	:	:	:	:	:	:	:	:	:
	:	:	:	:	:	:	:	:	:	:	:	:	:	:	:	:	:	:	:
	Green(61)	0	0	0	0	0	0	1	1	1	1	0	1	0	0	0	0	0	0
	Green(62)	0	0	0	0	0	0	1	1	1	1	1	0	0	0	0	0	0	0
Green(63)	0	0	0	0	0	0	1	1	1	1	1	1	0	0	0	0	0	0	
Gray Scale Of Blue	Blue(0)/Dark	0	0	0	0	0	0	0	0	0	0	0	0	0	0	0	0	0	0
	Blue(1)	0	0	0	0	0	0	0	0	0	0	0	0	0	0	0	0	0	1
	Blue(2)	0	0	0	0	0	0	0	0	0	0	0	0	0	0	0	0	1	0
	:	:	:	:	:	:	:	:	:	:	:	:	:	:	:	:	:	:	:
	:	:	:	:	:	:	:	:	:	:	:	:	:	:	:	:	:	:	:
	:	:	:	:	:	:	:	:	:	:	:	:	:	:	:	:	:	:	:
	Blue(61)	0	0	0	0	0	0	0	0	0	0	0	0	1	1	1	1	0	1
	Blue(62)	0	0	0	0	0	0	0	0	0	0	0	0	1	1	1	1	1	0
Blue(63)	0	0	0	0	0	0	0	0	0	0	0	0	1	1	1	1	1	1	

Note (1) 0: Low Level Voltage, 1: High Level Voltage

6. INTERFACE TIMING

6.1 INPUT SIGNAL TIMING SPECIFICATIONS

The input signal timing specifications are shown as the following table and timing diagram.

Signal	Item	Symbol	Min.	Typ.	Max.	Unit	Note
DCLK	Frequency	Fc	22.66	25.175	27.69	MHz	
Vertical Active Display Term	Total	Tv	515	525	535	Th	Tv=Tvd+Tvb
	Display	Tvd	-	480	-	Th	-
	Blank	Tvb	35	45	55	Th	-
Horizontal Active Display Term	Total	Th	750	800	850	Tc	Th=Thd+Thb
	Display	Thd	-	640	-	Tc	-
	Blank	Thb	110	160	210	Tc	-

Note (1) Since this assembly is operated in DE only mode. Otherwise, this assembly would operate abnormally.

(2) Frame rate is 60Hz

INPUT SIGNAL TIMING DIAGRAM

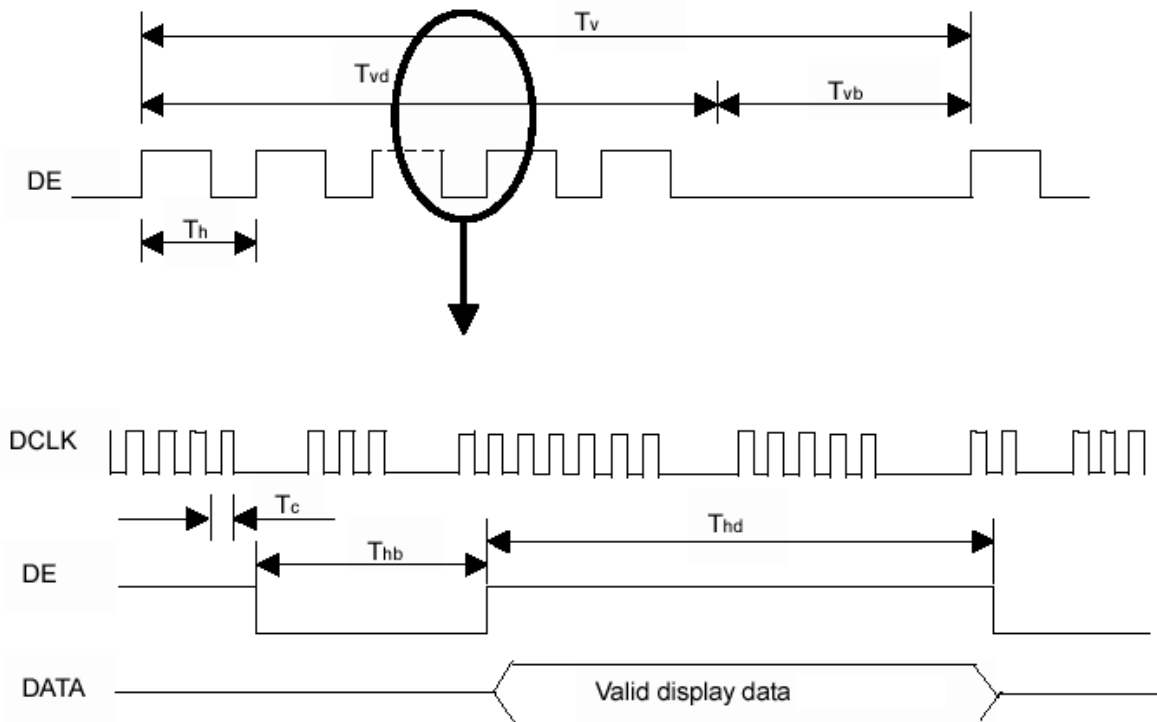

6.2 DE +Sync Mode INPUT SIGNAL TIMING SPECIFICATIONS

The input signal timing specifications are shown as the following table and timing diagram.

Signal	Item	Symbol	Min.	Typ.	Max.	Unit	Note
DCLK	Frequency	Tc	22.66	25.175	27.69	MHZ	
Vertical Active Display Term	Total	Tv	515	525	535	Th	
	Display	Tvd	-	480	-	Th	
	Front Porch	Tvf	-	7	-	Th	
	Back Porch	Tvb	-	35	-	Th	
	VS Pluse width	Tvp	1	3	5	Th	
Horizontal Active Display Term	Total	Th	750	800	850	Tc	
	Display	Thd	-	640	-	Tc	
	Front Porch	Thf	-	16	-	Tc	
	Back Porch	Thb	107	114	125	Tc	
	HS Pluse width	Thp	5	30	50	Tc	

Note (1) Since this assembly is operated in DE only mode, Hsync and Vsync input signals should be set to low logic level. Otherwise, this assembly would operate abnormally.

(2) Frame rate is 60Hz

INPUT SIGNAL TIMING DIAGRAM

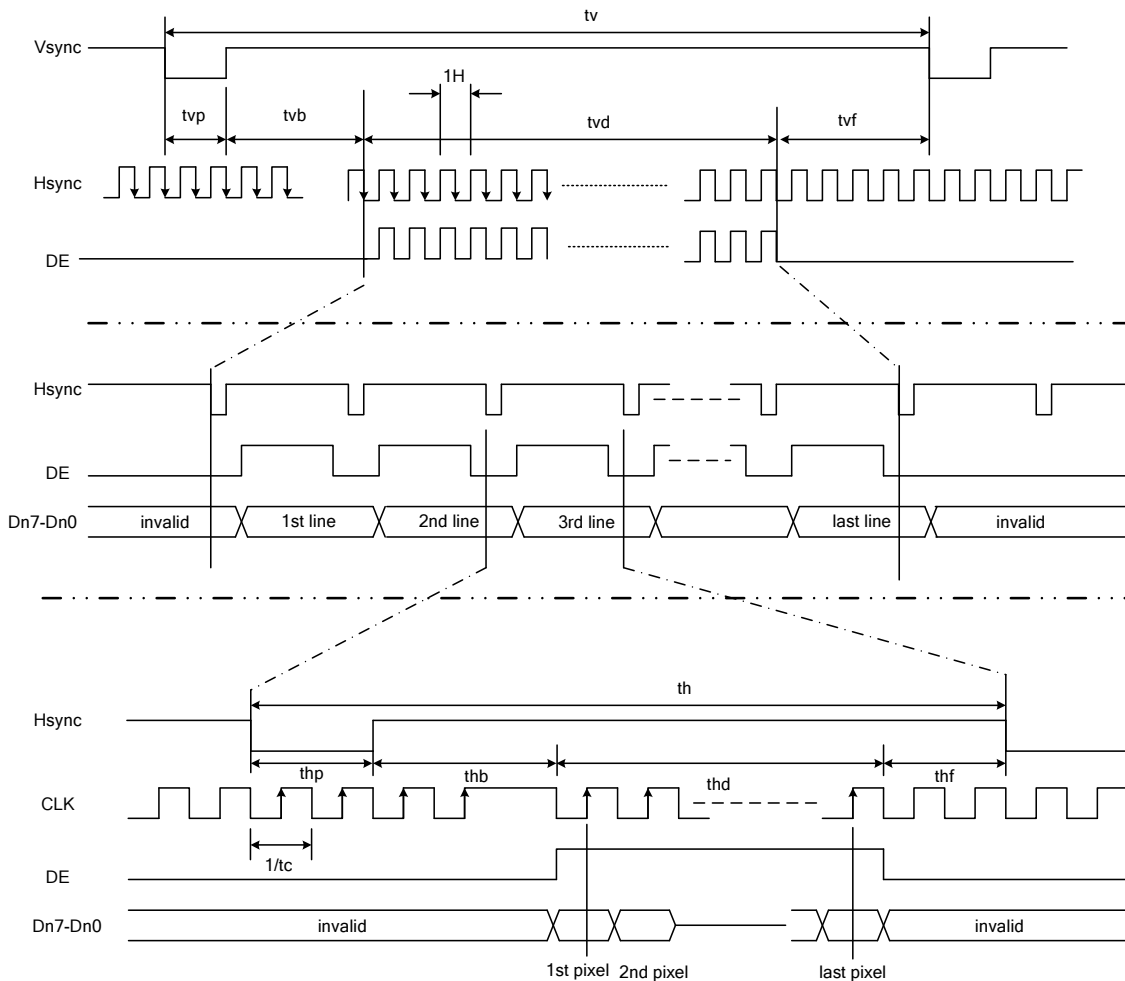

6.3 POWER ON/OFF SEQUENCE

To prevent a latch-up or DC operation of LCD assembly, the power on/off sequence should be as the diagram below.

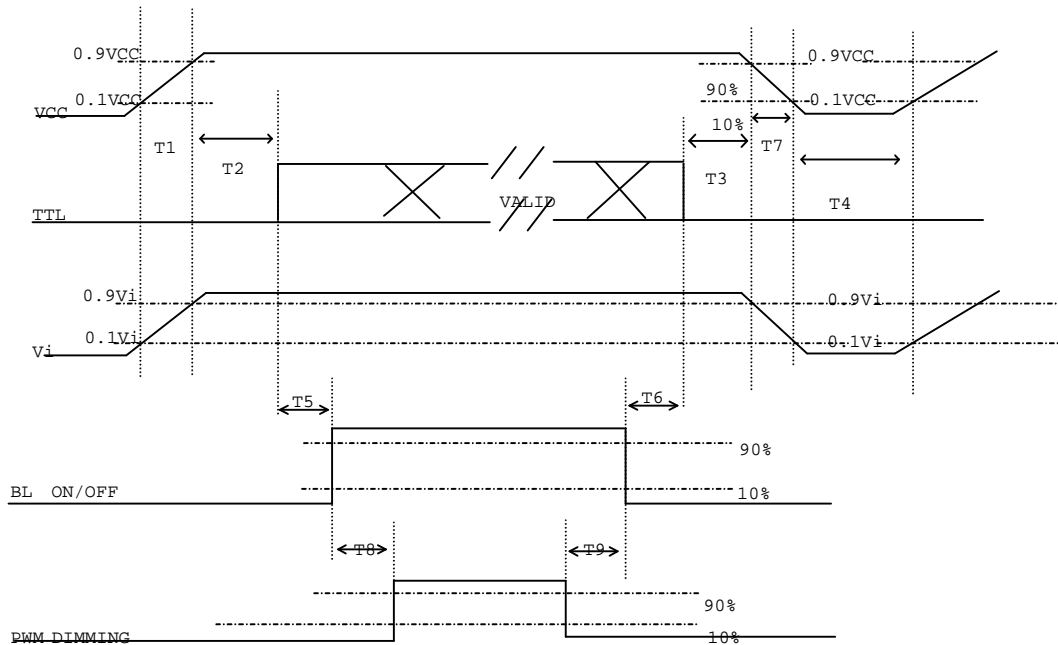

Power ON/OFF sequence

Note (1) Please avoid floating state of interface signal at invalid period.

Note (2) When the interface signal is invalid, be sure to pull down the power supply of LCD VCC to 0 V.

Note (3) The Backlight converter power must be turned on after the power supply for the logic and the interface signal is valid. The Backlight converter power must be turned off before the power supply for the logic and the interface signal is invalid.

Parameter	Value			Units
	Min	Typ	Max	
T1	0.5	-	10	ms
T2	0	-	50	ms
T3	0	-	50	ms
T4	500	-	-	ms
T5	200	-	-	ms
T6	200	-	-	ms
T7	5	-	300	ms
T8	10	-	-	ms
T9	10	-	-	ms

7. OPTICAL CHARACTERISTICS

7.1 TEST CONDITIONS

Item	Symbol	Value	Unit
Ambient Temperature	Ta	25±2	°C
Ambient Humidity	Ha	50±10	%RH
Supply Voltage	V _{CC}	3.3	V
Input Signal	According to typical value in "3. ELECTRICAL CHARACTERISTICS"		
Converter Voltage	V _{in}	12	V
Converter Duty		100%	

7.2 OPTICAL SPECIFICATIONS

The relative measurement methods of optical characteristics are shown in 7.2. The following items should be measured under the test conditions described in 7.1 and stable environment shown in Note (5).

Item		Symbol	Condition	Min.	Typ.	Max.	Unit	Note					
Color Chromaticity	Red	Rx	$\theta_x=0^\circ, \theta_y=0^\circ$ CS-1000	Typ - 0.05	0.588	Typ + 0.05	-	(1), (5)					
		Ry			0.339		-						
	Green	Gx			0.332		-						
		Gy			0.587		-						
	Blue	Bx			0.146		-						
		By			0.097		-						
	White	Wx			0.313		-						
		Wy			0.329		-						
	Center Luminance of White				L _C				350	450		-	-
	Contrast Ratio				CR				600	800			-
Response Time		T _R	$\theta_x=0^\circ, \theta_y=0^\circ$	-	15			ms					
		T _F		-	35			ms					
White Variation		δW	$\theta_x=0^\circ, \theta_y=0^\circ$	-	1.25	1.4		-					
Viewing Angle	Horizontal	θ_{x+}	CR≥10	70	80	-	Deg.	(1), (5)					
		θ_{x-}		70	80	-							
	Vertical	θ_{y+}		60	70	-							
		θ_{y-}		60	70	-							

Note (1) Definition of Viewing Angle (θ_x, θ_y):

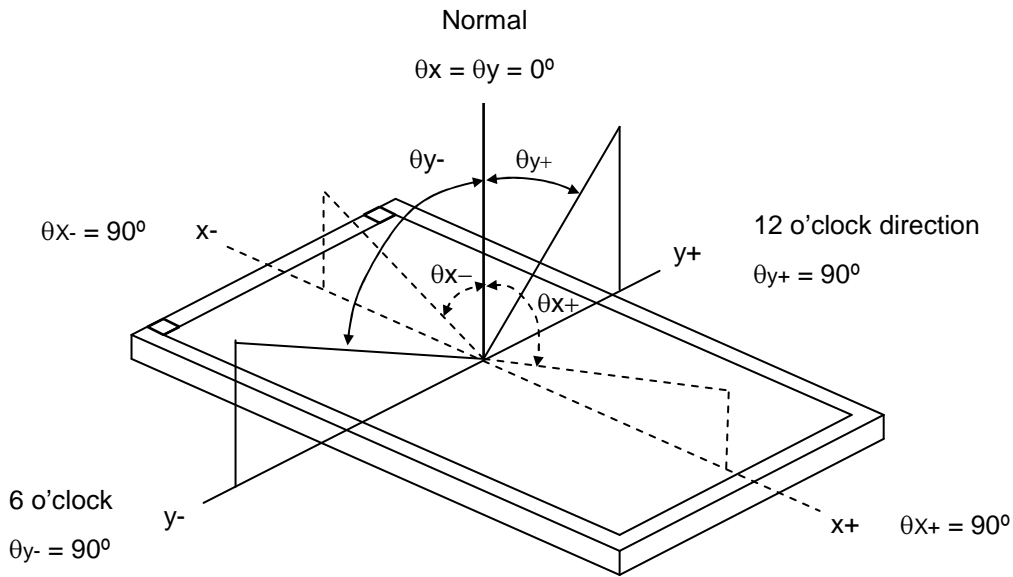

Note (2) Definition of Contrast Ratio (CR):

The contrast ratio can be calculated by the following expression.

$$\text{Contrast Ratio (CR)} = L_{63} / L_0$$

L63: Luminance of gray level 63

L 0: Luminance of gray level 0

$$\text{CR} = \text{CR} (5)$$

CR (X) is corresponding to the Contrast Ratio of the point X at Figure in Note (6).

Note (3) Definition of Response Time (T_R, T_F) and measurement method:

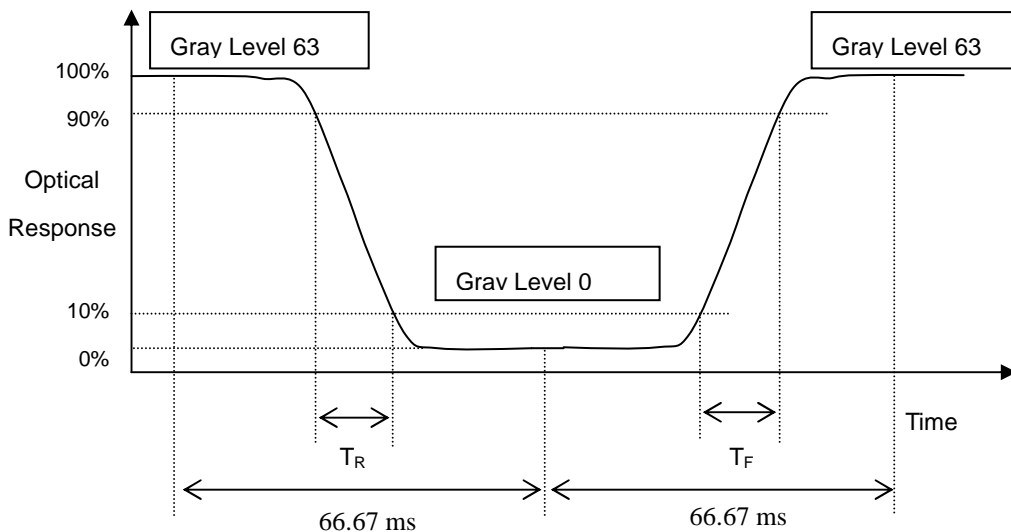

Note (4) Definition of Luminance of White (L_C):

Measure the luminance of gray level 63 at center point

$$L_c = L(5)$$

L(x) is corresponding to the luminance of the point X at Figure in Note (6).

Note (5) Measurement Setup:

The LCD module should be stabilized at given temperature for 20 minutes to avoid abrupt temperature change during measuring. In order to stabilize the luminance, the measurement should be executed after lighting Backlight for 20 minutes in a windless room.

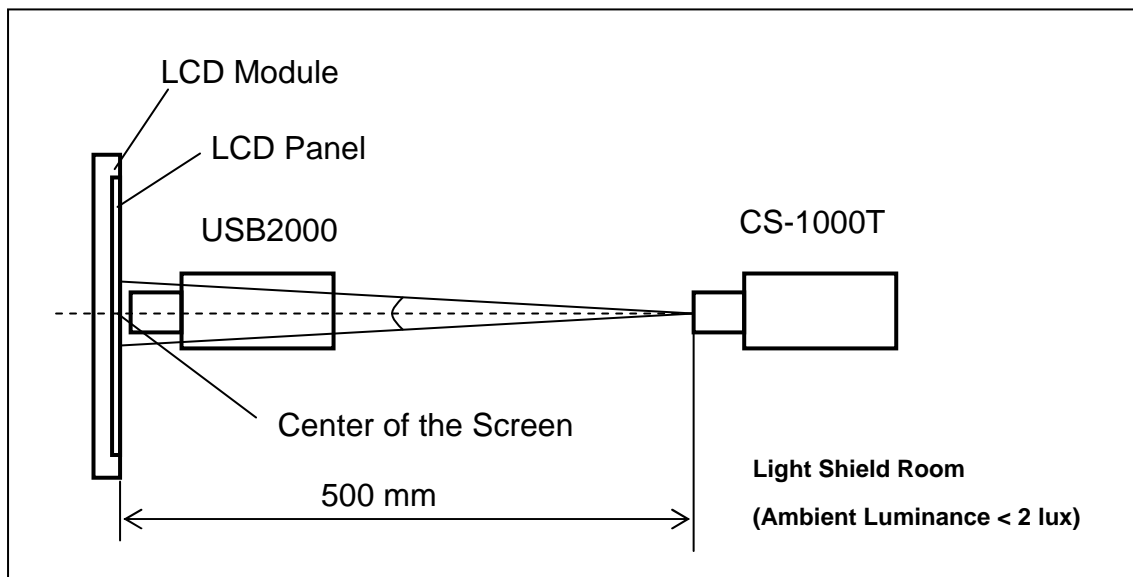

Note (6) Definition of White Variation (δW):

Measure the luminance of gray level 63 at 5 points

$$\delta W = \frac{\text{Maximum [L (1), L (2), L (3), L (4), L (5)]}}{\text{Minimum [L (1), L (2), L (3), L (4), L (5)]}}$$

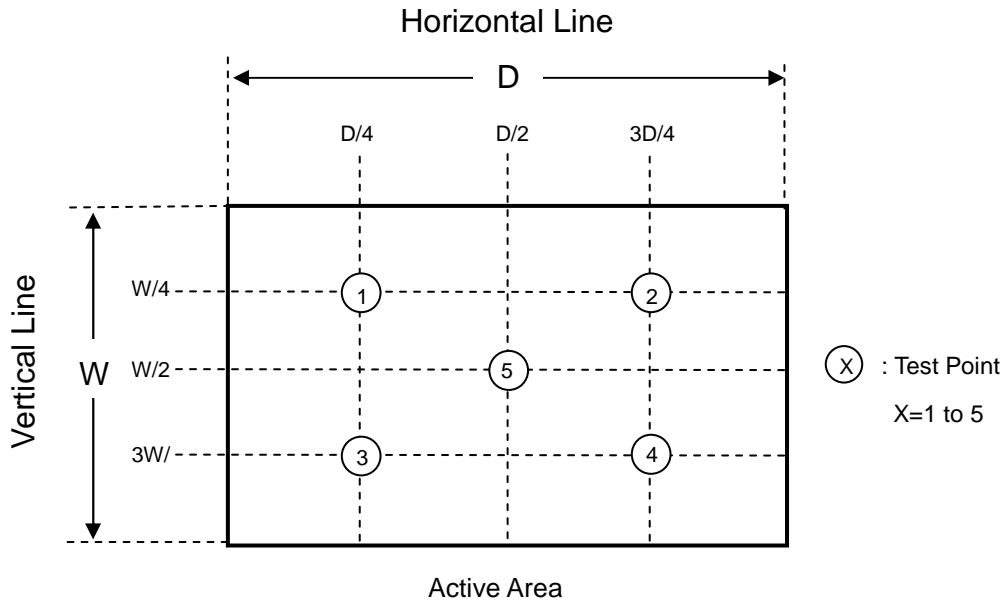

8. RELIABILITY TEST CRITERIA

Test Item	Test Condition	Note
High Temperature Storage Test	85°C, 240 hours	(1)(2)
Low Temperature Storage Test	-30°C, 240 hours	
Thermal Shock Storage Test	-30°C, 0.5hour \longleftrightarrow 85°C, 0.5hour; 1hour/cycle,100cycles	
High Temperature Operation Test	85°C, 240 hours	
Low Temperature Operation Test	-30°C, 240 hours	
High Temperature & High Humidity Operation Test	60°C, 90%RH, 240hours	
Shock (Non-Operating)	50G, 11ms, half sine wave, 1 time for $\pm X$, $\pm Y$, $\pm Z$ direction	(3)
Vibration (Non-Operating)	1.5G, 10 ~ 300 Hz, 10min/cycle, 3 cycles each X, Y, Z	(3)

Note (1) There should be no condensation on the surface of panel during test.

Note (2) Temperature of panel display surface area should be 80 °C Max.

Note (3) At testing Vibration and Shock, the fixture in holding the module has to be hard and rigid enough so that the module would not be twisted or bent by the fixture.

Note (4) In the standard conditions, there is no function failure issue occurred. All the cosmetic specifications are judged before reliability test.

9. PACKAGING

9.1 PACKING SPECIFICATIONS

- (1) 60pcs LCD modules / 1 Box
- (2) Box dimensions: 500 (L) X 400 (W) X 330 (H) mm
- (3) Weight: approximately 11.65Kg (60 modules per box)

9.2 PACKING METHOD

(1) Carton Packing should have no failure in the following reliability test items.

Test Item	Test Conditions	Note
Vibration	ISTA STANDARD Random, Frequency Range: 2 – 200 Hz Top & Bottom: 30 minutes (+Z), 10 min (-Z), Right & Left: 10 minutes (X) Back & Forth 10 minutes (Y)	Non Operation
Dropping Test	1 Angle, 3 Edge, 6 Face, 46 cm	Non Operation

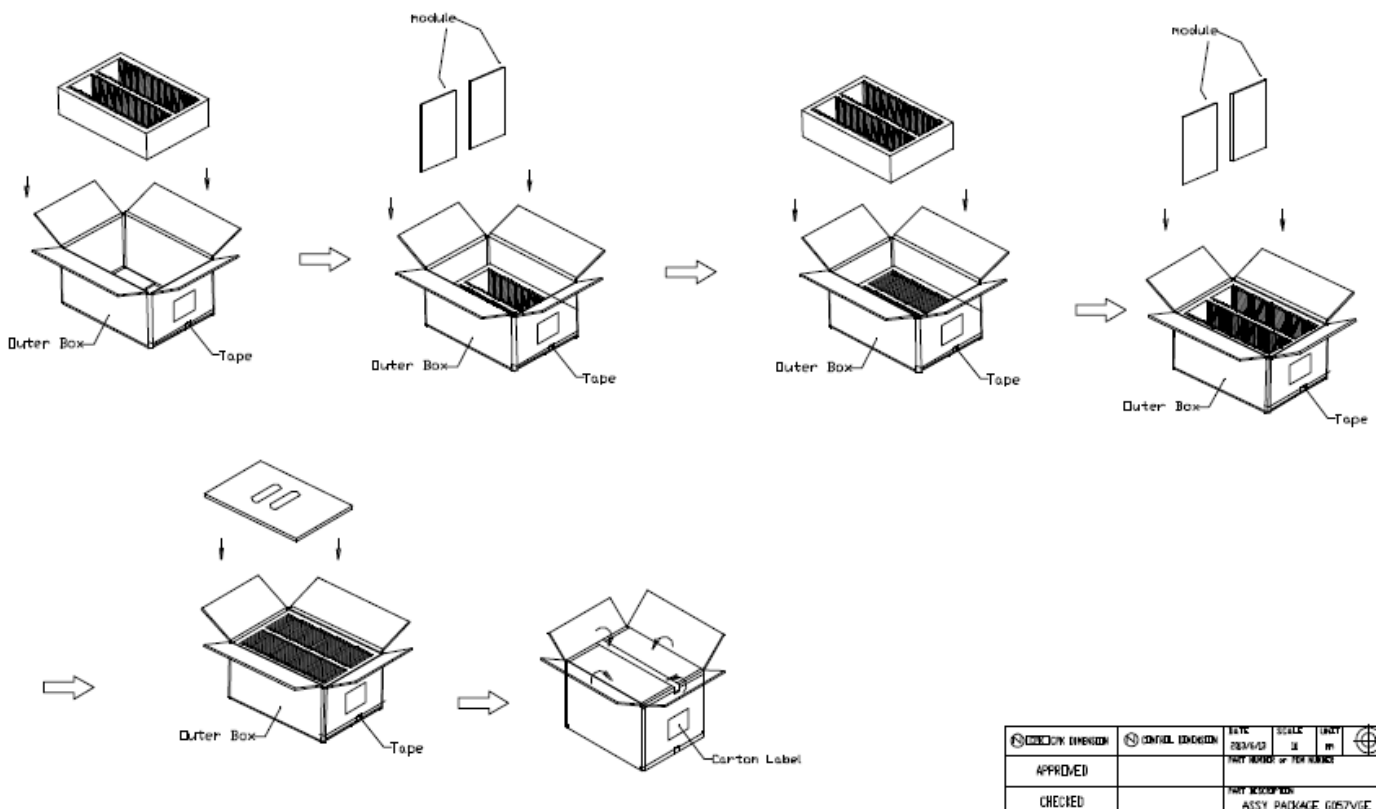

CONTROL ENGINEER	CONTROL ENGINEER	DATE	SCALE	UNIT	
APPROVED		2014/03	1:1	mm	
CHECKED		PART NUMBER: ASSY_PACKAGE_6057V0E			

Figure. 9-1 Packing method

Air/ Sea / Land Transportation (40ft /40ft HQ Container)

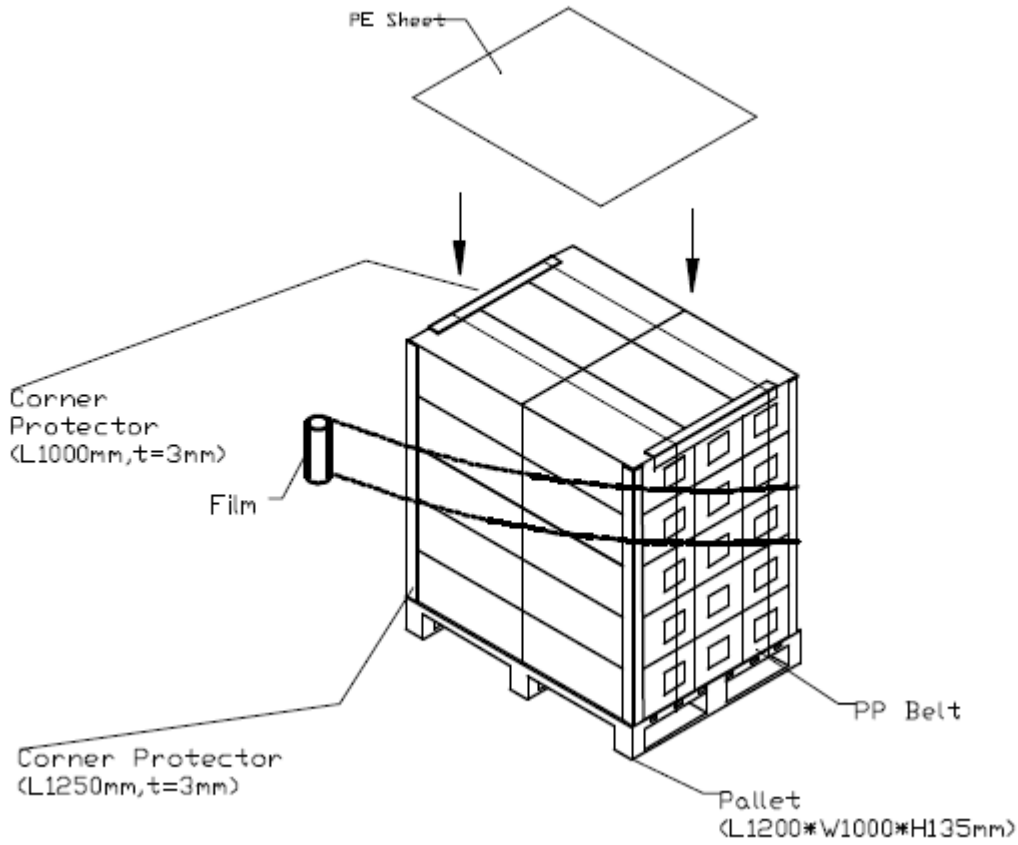

Figure. 9-2 Packing method

9.3 UN-PACKING METHOD

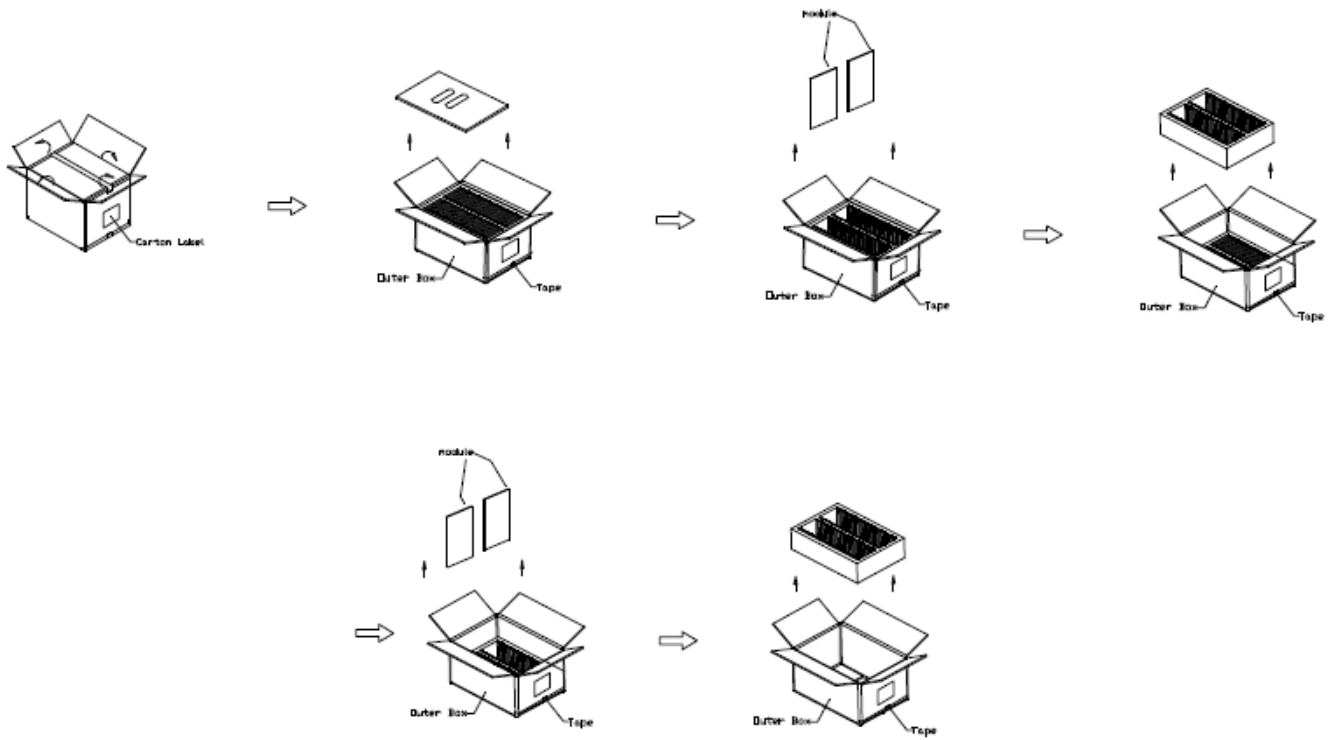
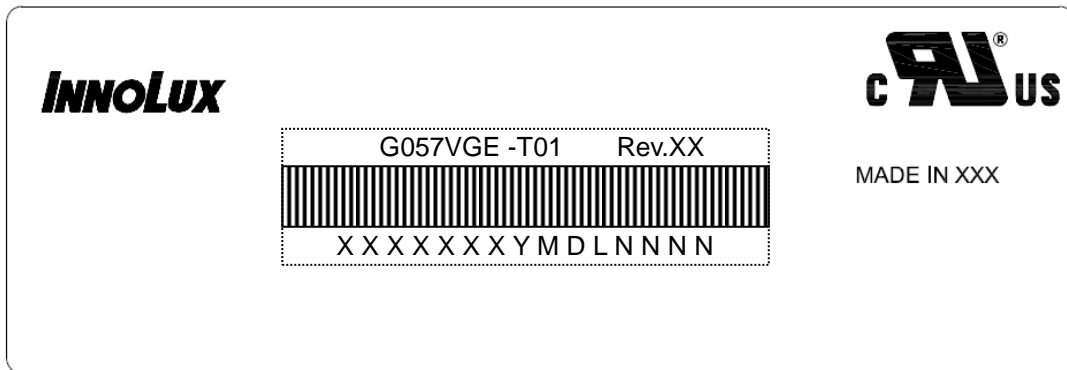

Figure. 9-3 Un-packing method

10. DEFINITION OF LABELS

10.1 INX MODULE LABEL



The barcode nameplate is pasted on each module as illustration, and its definitions are as following explanation.

- (a) Model Name: G057VGE-T01
- (b) Revision: Rev. XX, for example: A1, ...C1, C2 ...etc.
- (c) Serial ID: X X X X X X Y M D X N N N N

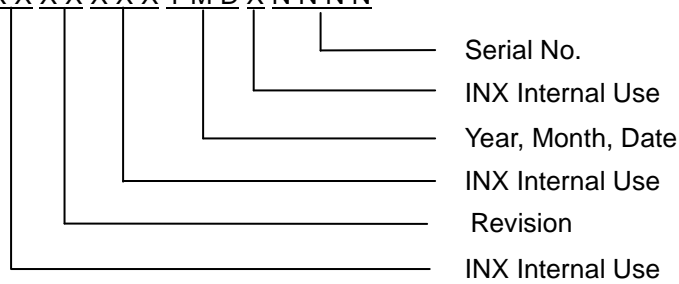

Serial ID includes the information as below:

- (a) Manufactured Date: Year: 0~9, for 2010~2019
 Month: 1~9, A~C, for Jan. ~ Dec.
 Day: 1~9, A~Y, for 1st to 31st, exclude I, O and U
- (b) Revision Code: cover all the change
- (c) Serial No.: Manufacturing sequence of product

11. PRECAUTIONS

11.1 ASSEMBLY AND HANDLING PRECAUTIONS

- (1) Do not apply rough force such as bending or twisting to the module during assembly.
- (2) To assemble or install module into user's system can be only in clean working areas. The dust and oil may cause electrical short or worsen the polarizer.
- (3) It's not permitted to have pressure or impulse on the module because the LCD panel and Backlight will be damaged.
- (4) Always follow the correct power sequence when LCD module is connecting and operating. This can prevent damage to the CMOS LSI chips during latch-up.
- (5) Do not pull the I/F connector in or out while the module is operating.
- (6) Do not disassemble the module.
- (7) Use a soft dry cloth without chemicals for cleaning, because the surface of polarizer is very soft and easily scratched.
- (8) It is dangerous that moisture come into or contacted the LCD module, because moisture may damage LCD module when it is operating.
- (9) High temperature or humidity may reduce the performance of module. Please store LCD module within the specified storage conditions.
- (10) When ambient temperature is lower than 10°C may reduce the display quality. For example, the response time will become slowly.
- (11) Do not keep same pattern in a long period of time. It may cause image sticking on LCD.

11.2 SAFETY PRECAUTIONS

- (1) Do not disassemble the module or insert anything into the Backlight unit.
- (2) If the liquid crystal material leaks from the panel, it should be kept away from the eyes or mouth. In case of contact with hands, skin or clothes, it has to be washed away thoroughly with soap.
- (3) After the module's end of life, it is not harmful in case of normal operation and storage.

12. MECHANICAL CHARACTERISTICS

